

Stacker

Ms. Stacker™

CHICAGO®



Ms. Stacker is a simple high speed conveyor aid for the automatic counting and stacking or folding, counting, and stacking of small articles such as wiper cloths, napkins, face cloths and similar small items. Ms. Stacker will increase operator output, reduce fatigue and eliminate errors in the preparation and stacking of small flat articles into pre-counted packs. Counts of up to 100 can be pre-selected (depending on item thickness). Completed stacks are automatically discharged and the system resets for repeat operation. The unit also has a folding mechanism on the infeed conveyor that will enable larger articles, more than 24" (600 mm) long, such as barber towels or hand towels, to be folded in half prior to counting and stacking.

Stacking Operation

Articles are manually fed to the unit where they are counted and placed one on top of the other to form a stack. For a one operator system, the completed stacks are conveyed to a position where the operator can easily remove them. Alternatively the stacks can be conveyed forward from the machine discharge point.

Ms. Stacker

Dimensions and Utilities

NOTE:

1. Specifications subject to change without notice. Consult factory for certified construction floorplan.
2. Millimeter dimensions are in [].
3. All dimensions are +/- 1/2".
4. Utility connections are located as shown.

NOTE:

1. Specifications subject to change without notice. Consult factory for certified construction floorplan.
2. Millimeter dimensions are in [].
3. All dimensions are +/- 1/2".
4. Discharge may be reversed in field.

CONNECTION(S)	DIA.	HEIGHT
Ⓐ Air Connection	1/4"	8-1/2" [216]
Ⓓ Compressed Air Drain	1/4"	4-1/2" [114]
Ⓔ Electrical Connection	-	28" [711]

Top View

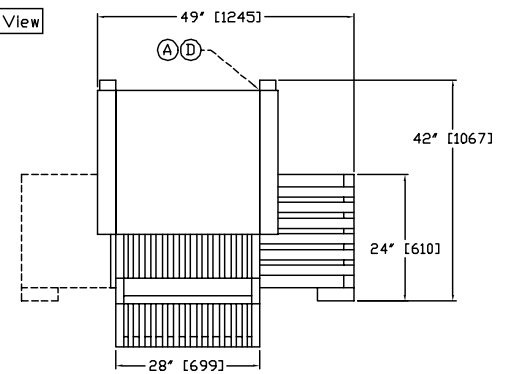

Side View

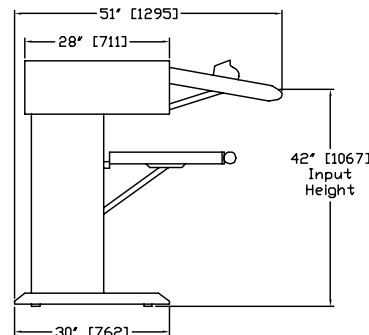

Front View

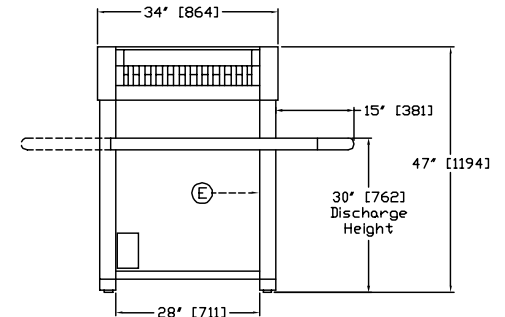

Features

Folding Operation

Ms. Stacker's feed conveyor is also equipped with a suction holding bridge above the input conveyor. The operator lays the leading edge of the item across the suction bridge. A vacuum then automatically switches on to momentarily hold the item. When the trailing edge of the item clears the item measuring switch, as the conveyor continues to move, the vacuum switches off, releasing the leading edge to fall in line with the trailing edge, thus folding the item in half. The unique folding mechanism uses no moving parts. This enables longer articles such as barber towels or hand towels to be folded in half prior to counting and stacking.

Capacity

Ms. Stacker will accept item sizes up to 24" x 24" (600 x 600 mm) for flat stacking. Items greater than 24" (600 mm) in length are folded in half by the folding bridge/blade mechanism and individually stacked on the exit conveyor as described above. When a preset count is reached, the stack is advanced from the drop area. Maximum piece width that can be stacked is 24" (600 mm). Consult factory for special model to accommodate larger item sizes up to 40" x 40" (1000 x 1000 mm) or for multi-lane models to work in conjunction with other automated multi-lane ironing/folding equipment.

A Complete Range of Separating, Feeding, Ironing, Folding, and Sorting Options

Because Chicago specializes only in flatwork finishing equipment, it can offer the world's widest range of high production separating, feeding, ironing, folding, and sorting equipment. Complete flatwork finishing systems range from automated multi-roll systems producing over 2000 pounds per hour to compact ironers for small on-premise laundries.

Chicago's performance record is unmatched in thousands of installations in commercial, textile rental, institutional, and on-premise laundries. An experienced Chicago professional will be pleased to make an objective equipment recommendation based on your production, space, utility, and budget requirements.

Contact your local Chicago distributor or the factory sales assistance office for a no-obligation analysis of your needs.



CHICAGO DRYER COMPANY
2200 North Pulaski Road
Chicago, Illinois 60639-3737 USA

Phone • 773.235.4430
Fax • 773.235.4439
Web • www.chidry.com
Email • chicago@chidry.com